

CNC kit notes.

The assembly of the TW28 CNC kit proceeds exactly as described in the TW28 building notes.

See the PDF files included in your kit for the nesting of the plywood. The nesting is slightly different from what we show on the plans mostly because of the router bit clearance on the CNC machine.

PDF files:

There are more than 50 PDF files, one for each plywood sheet plus some assembly drawings. Print them as needed.

Layout drawings:

- TW28_all.PDF shows the CNC nesting of all the sheets. The sheets are numbered from the top left, one row at a time.
- TW28_frame_puzzle1.PDF : shows how the frames and sole parts are assembled. Same for _puzzle2, 3 etc. Some of the parts names are mirrored as on the specific sheets.

Note all the small floor frame parts and the keel stubs.

#4 shows the sole pieces.

The parts are marked the same way on the sheet drawings.

Molds drawings:

- TW28_molds_sheet#.PDF show the molds, one drawing per sheet. Disregard the dimensions along the edges, those are for the CNC operator.

Note the lines: the lower ones mark the level of the Baseline and the higher ones mark the sheer line level. Use the BL to level the molds and the sheer line level to install a wide board across the jig to support the side panels.

This batten is shown in our TW28 building notes.

Most of the molds are in two pieces: line up at the fairbody (keel) and use the beam at the sheer give on the plans to check the width.

At the keel side, assemble with a gusset or a truss type nail plate. If you use a gusset, keep in mind interference: the gusset must go towards the middle of the boat.

Where the mold includes a keel stub, the keel stub is the gusset.

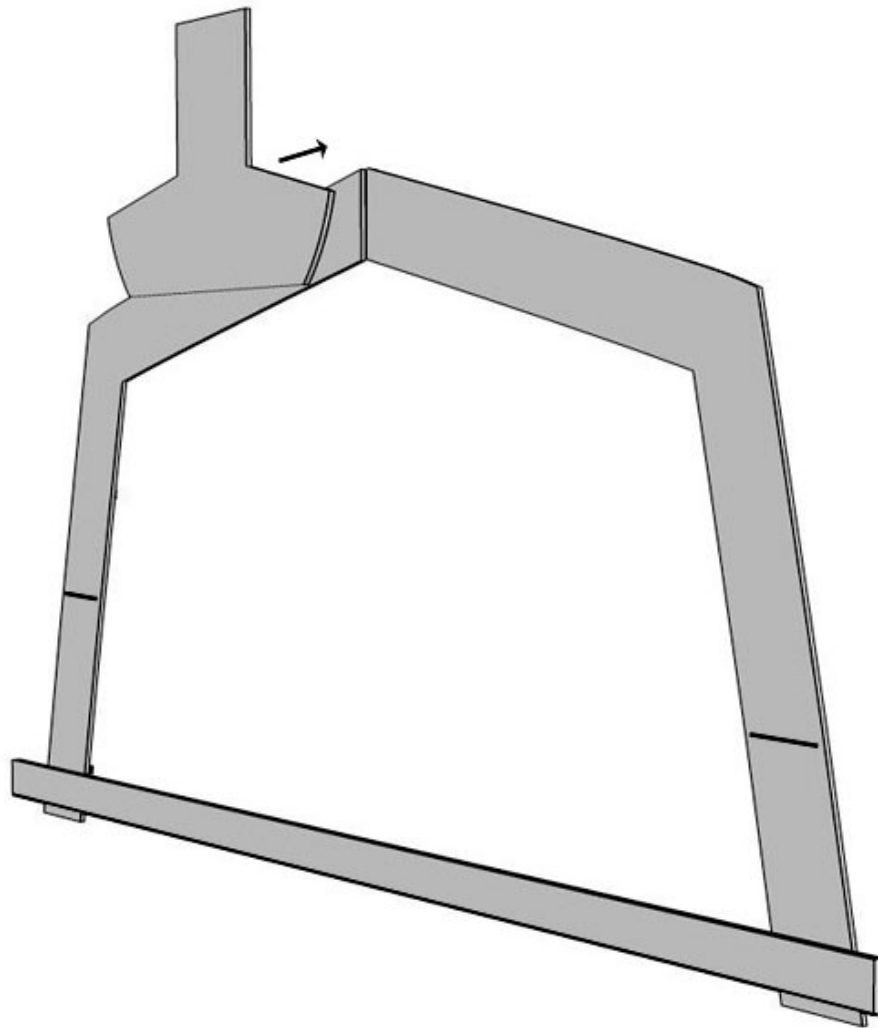

The drawing shows the board that will support the side panels, flush with the sheer line marked on the molds and further up, the marks for the baseline. Transfer them to the hull panels, you will use the marks for the sole installation. The keel gusset must be towards the middle of the boat.

The molds are located as on the plans. Use their "small" side. This means that you install the molds with thickness of the MDF towards the middle of the boat to avoid interference with the hull panels.

The plans show from which side that location is measured. For A, B, C and D, it is the bow side, for all others, it is the stern side.

The bow mold and the transom molds are fastened to mold A and Mold I respectively. This will require bracing with 2x4's. MDF panel leftovers can be used as spacers where needed.

Hull parts drawings:

Numbered from 9 to 56 with one exception: since the transom sheets are used first, on the jig they are labeled H1 and H2.

Some sheets are cut two times, we use one drawing for those sheets but skip the numbers.

Some remarks:

- Starting with H6, there are kerfs cut in the bottom panels. The kerfs do not go all the way to the edge, this makes handling easier but once installed on the boat, you may have to extend the kerf lines.
- Hull panels, sides and bottom: line up the panels before cutting the tabs and if possible, splice the panels together before cutting. It is possible to install the panels on the hull one at a time but the fairness will be better if you can assemble them on the shop floor.
- Bottom panel: in the kit, the opening for the keel is cut to fit around the keel stubs.

- The center of the hole in E keel stub is for shaft alignment: drill larger to fit shaft.